

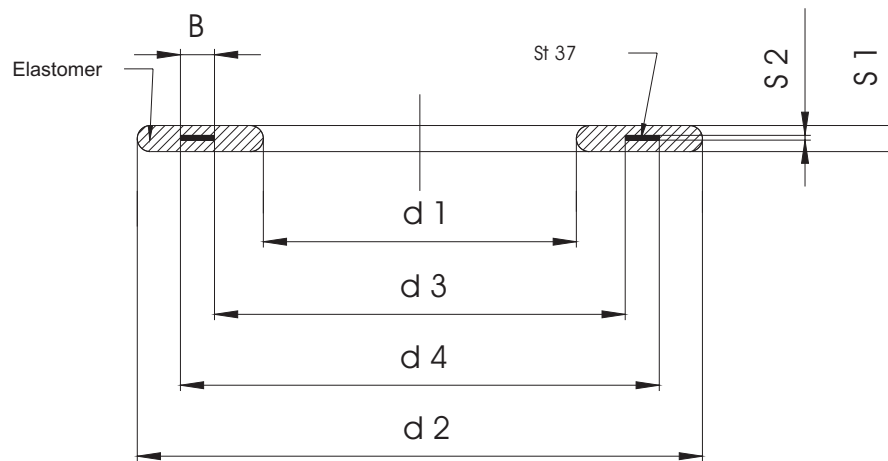

# 8000

## STEEL REINFORCED ELASTOMER GASKET



**WORKING PRESSURE** : PN 16

**STANDART** : DIN 2690

**WORKING PRESSURE** : PN 10

**STANDART** : DIN 2690

**GASKET**  
Table :D28

**STEEL SHEET (St 37)**

DN	d1	d2	S1	B	S2	d3	d4
25	35	70	4	5,5	1,0	45,0	56,0
32	43	82	4	8,0	1,0	55,0	71,0
40	49	92	4	8,0	1,0	58,0	74,0
50	61	107	4	8,0	1,0	72,0	88,0
65	77	127	4	8,5	1,0	86,0	103,0
80	90	142	4	10,0	1,0	104,0	124,0
100	115	162	5	10,5	1,0	123,0	142,0
125	141	192	5	11,5	1,0	153,0	176,0
150	169	218	5	11,5	1,0	176,0	199,0
200	220	273	6	10,0	1,5	236,5	256,5
250	274	330	6	10,0	1,5	292,0	312,0
300	325	385	6	10,0	1,5	345,0	365,0
350	368	445	7	10,0	1,5	396,5	416,5
400	420	497	7	10,0	1,5	448,5	468,5
450	470	557	7	16,0	2,0	497,5	529,5
500	520	618	7	16,0	2,0	553,0	585,0
600	620	735	7	16,0	2,0	661,5	693,5
700	720	805	8	16,0	2,0	746,5	778,5
800	820	910	8	16,0	2,0	849,0	881,0
900	920	1010	8	16,0	2,0	949,0	981,0
1000	1020	1125	8	16,0	2,0	1056,5	1088,5
1200	1220	1340	8	16,0	2,0	1264,0	1296,0
1400	1420	1545	8	20,0	3,0	1462,5	1502,5
1600	1620	1770	8	20,0	3,0	1675,0	1715,0
1800	1820	1970	8	30,0	3,0	1865,0	1925,0
2000	2020	2175	10	30,0	3,0	2066,5	2126,5
2200	2220	2384	10	30,0	3,0	2272	2332
2500	2520	2680	10	30,0	3,0	2570	2630

**GASKET**  
Table :D27

**STEEL SHEET (St 37)**

DN	d1	d2	S1	B	S2	d3	d4
25	35	70	4	5,5	1,0	45,0	56,0
32	43	82	4	8,0	1,0	55,0	71,0
40	49	92	4	8,0	1,0	58,0	74,0
50	61	107	4	8,0	1,0	72,0	88,0
65	77	127	4	8,5	1,0	86,0	103,0
80	90	142	4	10,0	1,0	104,0	124,0
100	115	162	5	10,5	1,0	123,0	142,0
125	141	192	5	11,5	1,0	153,0	176,0
150	169	218	5	11,5	1,0	176,0	199,0
200	220	273	6	10,0	1,5	236,5	256,5
250	274	330	6	10,0	1,5	292,0	312,0
300	325	385	6	10,0	1,5	345,0	365,0
350	368	445	7	10,0	1,5	396,5	416,5
400	420	497	7	10,0	1,5	448,5	468,5
450	470	557	7	16,0	2,0	497,5	529,5
500	520	595	7	16,0	2,0	541,5	573,5
600	620	695	7	16,0	2,0	641,5	673,5
700	720	805	8	16,0	2,0	746,5	778,5
800	820	910	8	16,0	2,0	849,5	881,0
900	920	1010	8	16,0	2,0	949,0	981,0
1000	1020	1125	8	16,0	2,0	1056,5	1088,5
1200	1220	1340	8	16,0	2,0	1264,0	1296,0
1400	1420	1545	8	20,0	3,0	1462,5	1502,5
1600	1620	1770	8	20,0	3,0	1675,0	1715,0
1800	1820	1970	8	30,0	3,0	1865,0	1925,0
2000	2020	2175	10	30,0	3,0	2066,5	2126,5
2200	2220	2384	10	30,0	3,0	2272	2332
2500	2520	2680	10	30,0	3,0	2570	2630