

# 7300-RS KNIFE GATE VALVE DIMENSIONAL DRAWING

Ø 50 - 1200

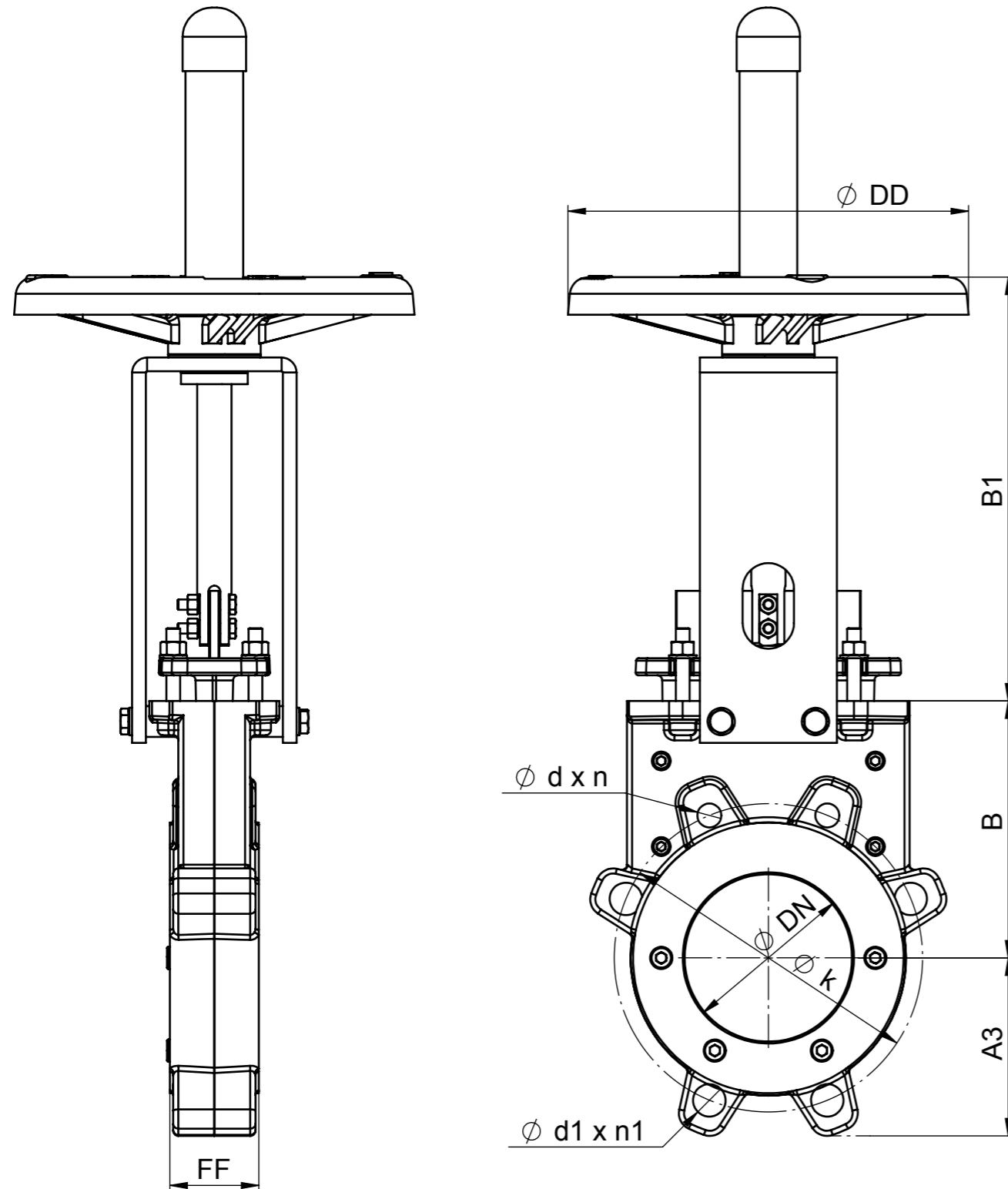

DN	A3	B	B1	ØDD	F	PN 10			Weight (kg)
						Øk	Ød (depth) x n	Ød1 x n1	
50	83	115	195	315	43	125	M 16 (10 mm) x 2	Ø19 x 2	9
65	93	120	225	315	46	145	M 16 (10 mm) x 2	Ø19 x 2	12
80	100	142	245	315	46	160	M 16 (10 mm) x 2	Ø19 x 6	14
100	113	145	270	315	52	180	M 16 (10 mm) x 2	Ø19 x 6	19
125	125	152	305	315	56	210	M 16 (10 mm) x 2	Ø19 x 6	22
150	145	178	390	315	56	240	M 20 (13 mm) x 4	Ø23 x 4	25
200	174	228	485	400	60	295	M 20 (14 mm) x 4	Ø23 x 4	45
250	200	246	520	400	68	350	M 20 (14 mm) x 6	Ø23 x 6	55
300	228	302	560	550	78	400	M 20 (18 mm) x 6	Ø23 x 6	90
350	253	350	650	550	92	460	M 20 (18 mm) x 6	Ø23 x 10	135
400	283	370	750	700	102	515	M 24 (25 mm) x 6	Ø28 x 10	180
500	335	464	960	700	127	620	M 24 (30 mm) x 8	Ø28 x 12	235
600	390	650	1070	700	154	725	M 27 (30 mm) x 8	Ø31 x 12	350
700	450	645	1085	800	165	840	M 27 (30 mm) x 10	Ø31 x 14	550
800	510	750	1162	800	190	950	M 30 (20 mm) x 24	-	750
1000	625	1300	1390	1000	216	1160	M 33 (38 mm) x 12	Ø37 x 16	1450
1200	730	1200	2300	1200	254	1380	M 36 (38 mm) x 12	Ø41 x 20	3300