

2160G

BUTTERFLY VALVE DIMENSIONAL DRAWING

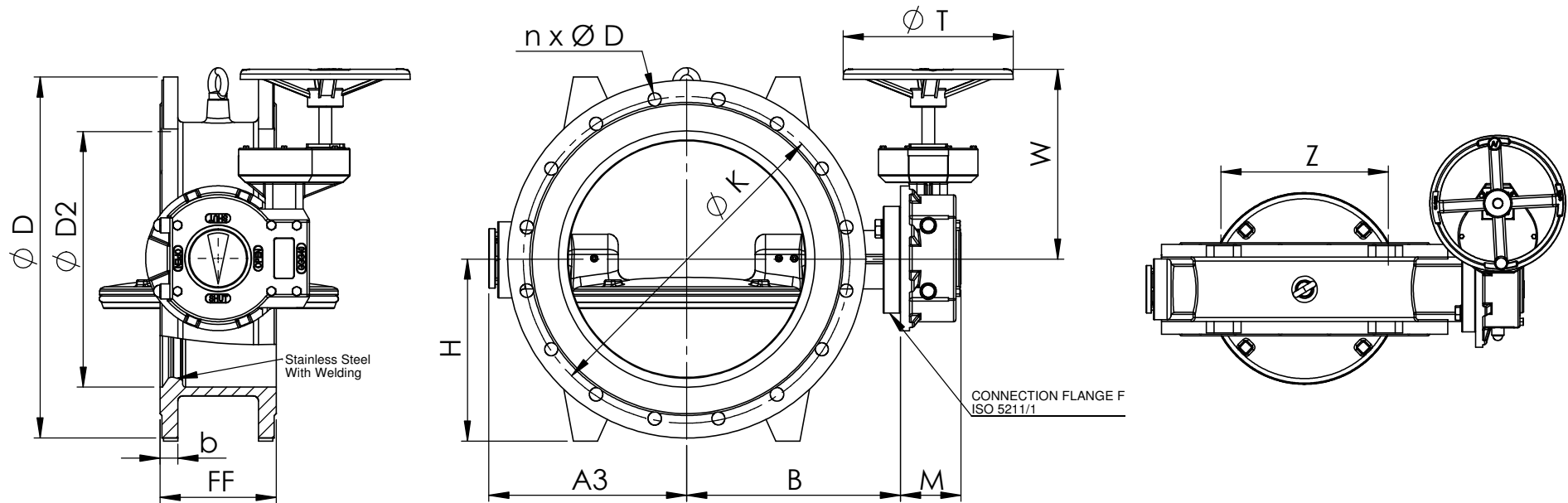

PN - 10								PN - 16						BODY								ISO 5211/1		FREE SHAFT Weight (kg)	GEAR BOX						
DN	b	ØD	ØD2	Ød	Øk	n		b	ØD	ØD2	Ød	Øk	n	PN10	PN16	PN10	PN16	PN10	PN16	H	FF	Ø T	W		Z	F		PN 10		PN 16	
														A3	A3	B	B	M	M							PN 10	PN 16	Type	Weight (kg)	Type	Weight (kg)
150	19	285	175	22	240	8		19	285	175	22	240	8	157	157	165	165	75	75	160	140	230	238	-	F 10	F 10	-				
200	20	340	205	22	295	8		20	340	205	22	295	12	183	183	213	213	75	75	190	152	230	238	95,7	F 10	F 10	-				
250	22	395	255	22	350	12		22	405	255	26	355	12	223	223	220	220	75	75	220	165	230	238	174,2	F 10	F 10	-				
300	24.5	455	300	22	400	12		24.5	460	300	26	410	12	245	245	273	273	75	75	250	178	230	238	215,9	F 10	F 10	-				
350	24.5	505	350	22	460	16		26.5	520	350	26	470	16	279	279	285	285	102	102	280	190	335	315	267	F 14	F 14	142,0	AST-40	12,240		
400	24.5	565	400	26	515	16		28	580	400	30	525	16	307	316	325	325	102	102	310	216	400	315	318,6	F 14	F 14	145,0	AST-60	17,900		
450	25.5	615	450	26	565	20		30	640	450	30	585	20	336	355	343	358	102	102	330	222	600	315	367	F 16	F 16	184,0	AST-80	32,660		
500	26.5	670	500	26	620	20		31.5	715	500	33	650	20	361	388	375	397	102	102	360	229	600	315	410	F 16	F 16	216,0				
600	30	780	600	30	725	20		36	840	600	36	770	20	420	451	435	465	102	102	440	267	600	315	516,2	F 16	F 25	-	AB1950N/SP4	58,000	AB1950N/SP4	58,000
700	32.5	895	700	30	840	24		39.5	910	700	36	840	24	473	494	488	503	135	135	465	292	600	414	586	F 25	F 30	625,0	AB6800NLT/SP4	100,000	AB6800N/SP4	100,000
800	35	1015	800	33	950	24		43	1025	800	39	950	24	554	566	550	580	135	135	540	318	600	414	682,8	F 30	F 30	-	AB6800N/SP4	100,000	AB6800N/SP6	111,000
900	37.5	1115	900	33	1050	28		46.5	1125	900	39	1050	28	600	600	620	640	225	225	570	330	600	525	780,5	F 30	F 35	1000,0	AB6800N/SP6	111,000	A250N/SP9	225,000
1000	40	1230	1000	36	1160	28		50	1255	1000	42	1170	28	683	698	682	682	225	225	676	410	600	525	871,7	F 35	F 35	1105,0	A250N/SP9	225,000	IW82	222,000
1200	45	1455	1200	39	1380	32		57	1485	1200	48	1390	32	795	845	800	800	225	225	735	470	600	525	1053,2	F 35	F 35	1846,0	IW82	222,000	IW9RA	262,000

Subject to change without notice,
Please contact us for other sizes and materials.
Part No: 37-150

REV:A

09.08.2012