

AV[®] 4010S

LASTİK SİTLİ ÇEKVALF ÖLÇÜ LİSTESİ

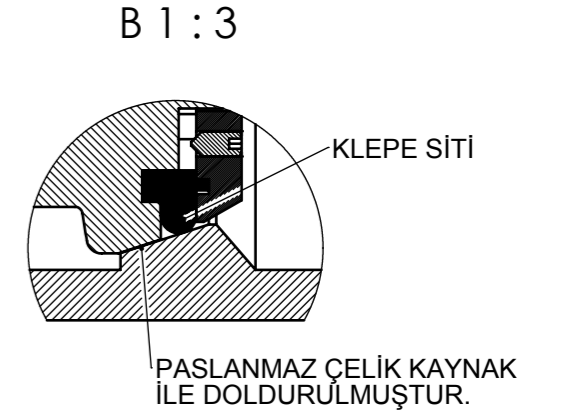
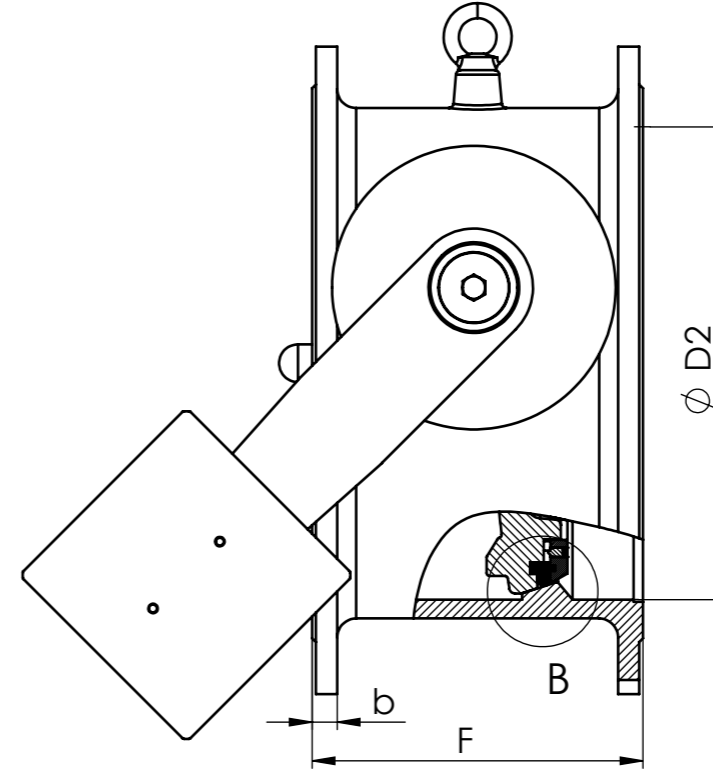
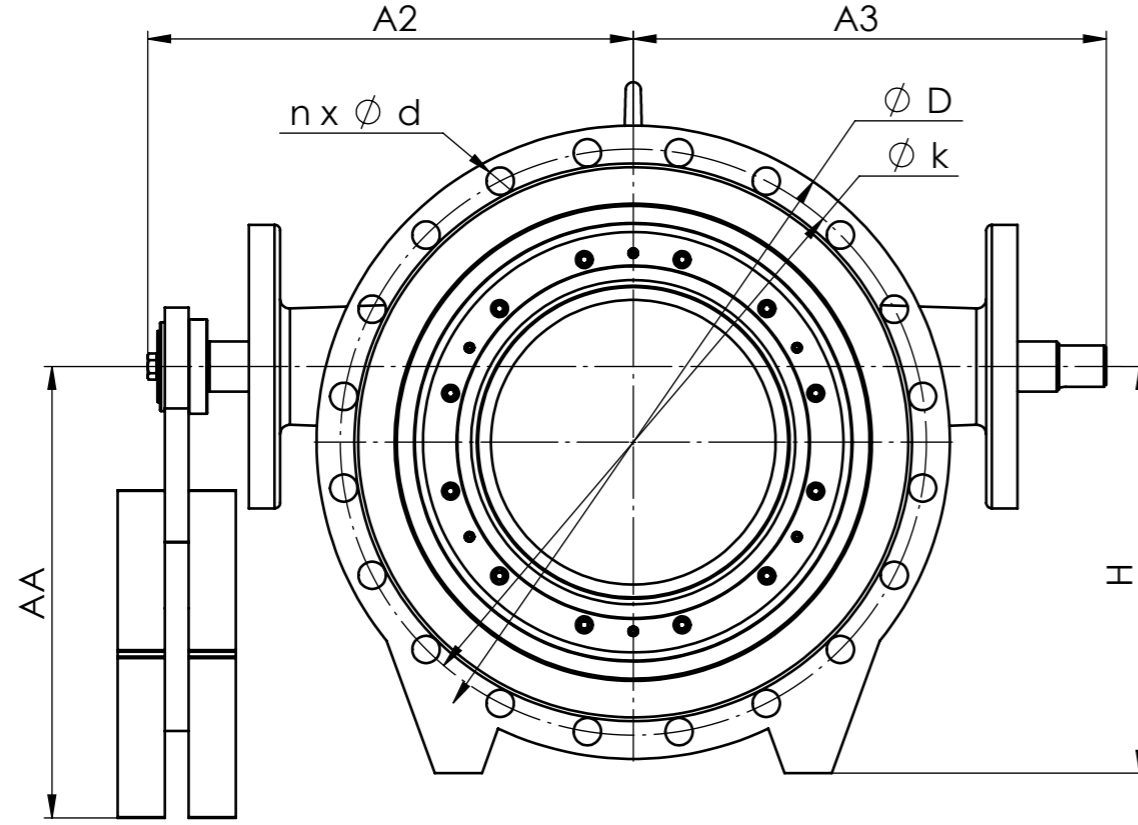

PN - 10 Flanş							PN - 16 Flanş					GÖVDE					
DN	b	ØD	ØD2	Ød	Øk	n	b	ØD	ØD2	Ød	Øk	n	AA	A2	A3	F	H
100	19	220	115	19	180	8	19	220	115	19	180	8	150	191	176	190	134
125	19	250	135	19	210	8	19	250	135	19	210	8	173	197	187	200	158
150	19	285	170	22	240	8	19	285	170	22	240	8	190	200	203	210	158
200	20	361	200	23	295	8	20	361	200	23	295	12	230	230	220	230	190
250	22	395	250	23	350	12	22	405	250	28	355	12	230	290	302	250	220
300	24.5	445	300	22	400	12	24.5	460	300	28	410	12	330	340	314	270	250
350	24.5	505	350	23	460	16	26.5	505	350	28	470	16	350	370	345	290	280
400	24.5	565	400	26	515	16	28	580	400	30	525	16	350	430	374	310	302
450	25.5	615	450	26	565	20	30	640	450	30	585	20	450	450	422	330	330
500	26.5	670	500	26	620	20	31.5	715	500	33	650	20	395	515	456	350	380
600	30	780	600	30	725	20	36	840	600	36	770	20	395	590	549	390	458
700	32.5	895	700	30	840	24	39.5	910	700	36	840	24	570	660	579	430	460
800	35	1015	800	33	950	24	43	1025	800	40	950	24	590	715	685	470	525
900	37.5	1115	900	33	1050	28	46.5	1125	900	39	1050	28	615	750	723	510	570
1000	40	1230	1000	36	1160	28	50	1255	1000	42	1170	28	1000	825	793	550	650
1200	45	1455	1200	40	1380	32	57	1485	1200	49	1390	32	1030	1025	1010	630	1044
1400	46	1675	1400	43	1590	36	60	1685	1400	49	1590	36	1080	1180	1160	710	1220
1600	49	1915	1600	49	1820	40	65	1930	1600	56	1820	40	1110	1310	1300	790	1280
2000	55	2325	2000	49	2230	48	75	2345	2000	62	2230	48	1176	1610	1600	950	1586