

ASTEKNIK

1130

TEK FLANŞLI KELEBEK VANA ÖLÇÜ LİSTESİ

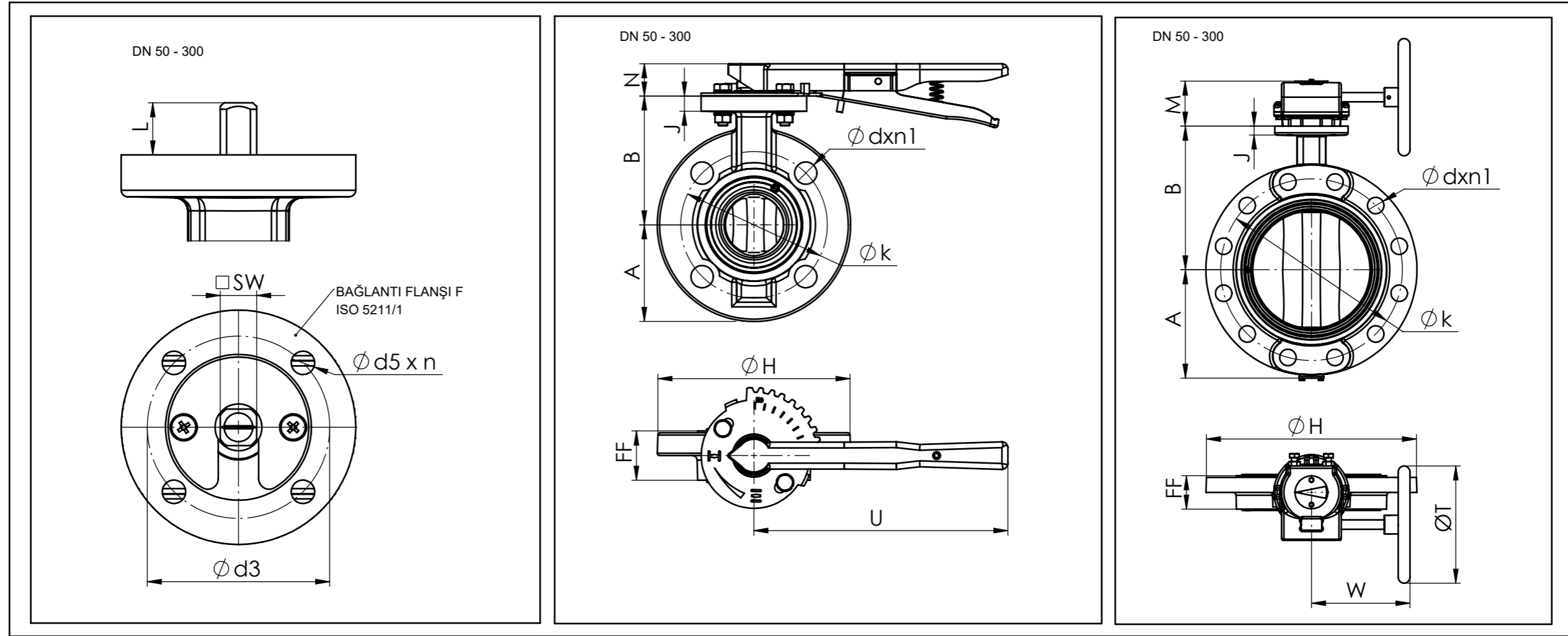

DN	A	B	FF	Ø H	J	M	N	U	W	Ø T	F	Ø d5xn	□ SW	L	Ø d3	PN 10			PN 16			MiL ÇIKIŞLI Ağırlık (kg)	KOL		DİŞLİ KUTU	
																Ø k	Ø d	n1	Ø k	Ø d	n1		Tip	Ağırlık (kg)	Tip	Ağırlık (kg)
Ø 50	82	108	43	165	13	50	37	220	159	125	05	7x4	□ 9	15	70	125	Ø 19	4	125	Ø 19	4	4.5	92-150	93.50	5,250	
Ø 65	93	127	46	185	13	50	37	220	159	125	05	7x4	□ 11	13	70	145	Ø 19	4	145	Ø 19	4	5.0	92-150	93.50		
Ø 80	102	132	46	200	14	50	37	220	159	125	05	7x4	□ 11	15	70	160	Ø 19	8	160	Ø 19	8	6.0	92-150	93.50		
Ø 100	117	155	52	220	14	50	37	260	159	125	05	7x4	□ 14	15	70	180	Ø 19	8	180	Ø 19	8	8.0	92-200	93.50		
Ø 125	127	158	56	250	14	50	37	260	159	125	05	7x4	□ 14	15	70	210	Ø 19	8	210	Ø 19	8	11.0	92-200	93.50		
Ø 150	142	185	56	285	14	50	37	350	159	160	07	9x4	□ 17	18	70	240	Ø 23	8	240	Ø 23	8	14.0	92-300	93.50		
Ø 200	170	213	60	340	15	50	37	350	159	160	07	9x4	□ 17	18	70	295	Ø 23	12	295	Ø 23	12	18.0	92-300	93.50		
Ø 250	212	245	68	395	15	75	47	400	238	200	10	9x4	□ 22	22	102	355	Ø 23	12	355	Ø 28	12	23.0	92-400	93.125	11,350	
Ø 300	240	282	78	445	15	75	47	400	238	230	10	11x4	□ 27	27	102	410	Ø 23	12	410	Ø 28	12	35.0	92-400	93.125		