

# ASTEKNIK 1140

## KULAKLI (DİŞLİ) TİP KELEBEK VANA ÖLÇÜ TABLOSU

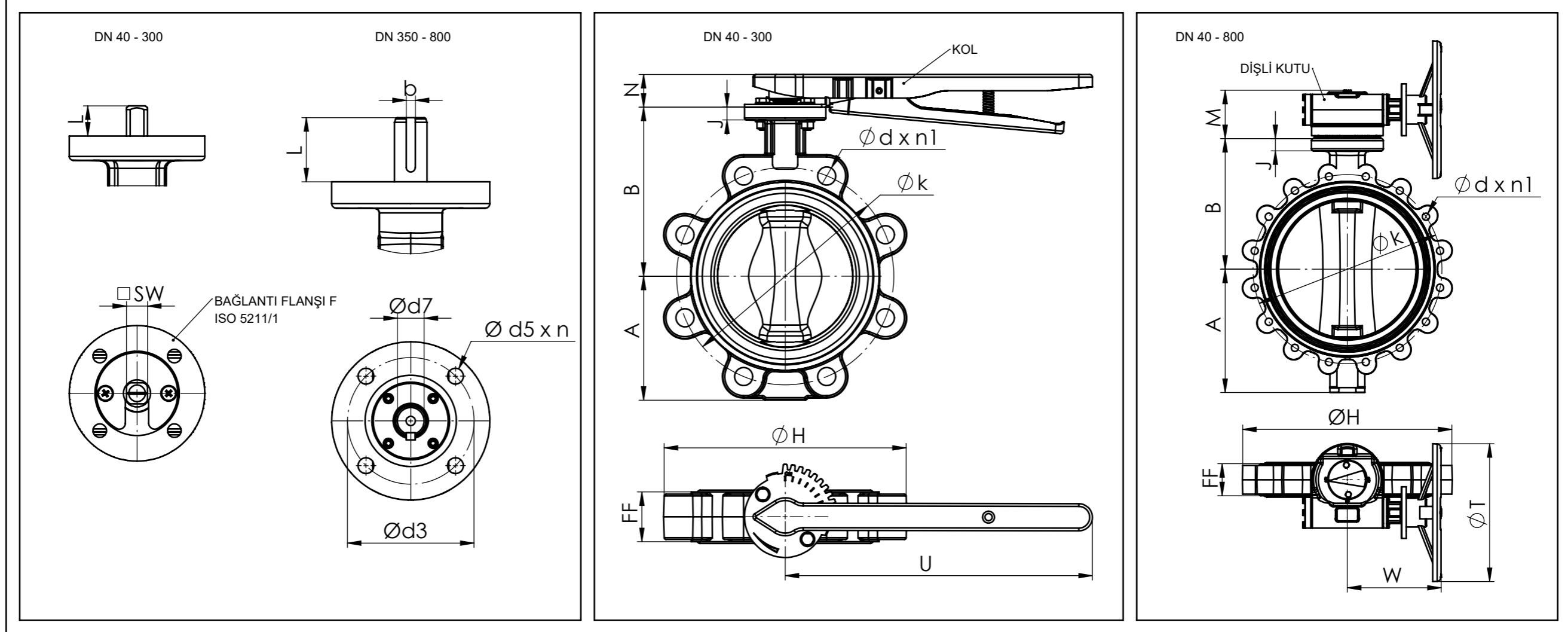

DN	A	B	FF	Ø H	J	M	N	U	W	Ø T	F	Ø d5xn	□ SW Ø d7	L	Ø d3	PN 10			PN 16			MİL ÇIKIŞLI Ağırlık (kg)	KOL		DİŞLİ KUTU				
																Ø k	Ø d	n1	Ø k	Ø d	n1		Ağırlık (kg)	Tip	Ağırlık (kg)	PN 10		PN 16	
																										Tip	Ağırlık (kg)	Tip	Ağırlık (kg)
Ø 40	61	99	40	118	14	76	37	220	159	125	05	7x4	□ 9	13	50	110	M 16	4	110	M 16	4	3.5	92-150	0.6	93.050	93.050	1.6	93.050	
Ø 50	67	110	43	130	14	76	37	220	159	125	05	7x4	□ 9	13	50	125	M 16	4	125	M 16	4	4	92-150	0.6	93.050	93.050	1.6	93.050	
Ø 65	75	129	46	154	16	76	37	220	159	125	07	9x4	□ 11	13	70	145	M 16	4	145	M 16	4	5	92-150	0.6	93.050	93.050	1.6	93.050	
Ø 80	96	134	46	188	16	76	37	220	159	125	07	9x4	□ 11	15	70	160	M 16	8	160	M 16	8	6	92-150	0.6	93.050	93.050	1.6	93.050	
Ø 100	111	157	52	218	16	76	37	260	159	125	07	9x4	□ 14	15	70	180	M 16	8	180	M 16	8	9	92-200	0.8	93.050	93.050	1.6	93.050	
Ø 125	123	160	56	234	16	76	37	260	159	125	07	9x4	□ 14	15	70	210	M 16	8	210	M 16	8	11	92-200	0.8	93.050	93.050	1.6	93.050	
Ø 150	134	187	56	268	16	76	37	350	159	160	07	9x4	□ 17	18	70	240	M 20	8	240	M 20	8	12	92-300	0.9	93.050	93.050	1.6	93.050	
Ø 200	164	205	60	317	16	76	37	350	159	160	07	9x4	□ 17	18	70	295	M 20	8	295	M 20	12	20	92-300	0.9	93.050	93.050	1.6	93.050	
Ø 250	202	245	68	393	16	81	47	400	238	200	10	11x4	□ 22	22	102	350	M 20	12	355	M 24	12	30	92-400	2.6	93.125	93.125	5.8	93.125	
Ø 300	239	282	77	446	16	81	47	400	238	230	10	11x4	□ 27	27	102	400	M 20	12	410	M 24	12	40	92-400	2.6	93.125	93.125	5.8	93.125	
Ø 350	300	318	78 / 92	513	28	117	-	-	315	335	14	17.5x4	Ø 36	75	140	460	M 20	16	470	M 24	16	66	-	-	93.260	17.5	93.260	17.5	93.260
Ø 400	326	362	102	570	28	117	-	-	315	335	14	17.5x4	Ø 36	75	140	515	M 24	16	525	M 27	16	81	-	-	93.260	30	93.350	30	93.350
Ø 450	364	410	114	632	26	120	-	-	315	400	16	22x4	Ø 45	92	165	565	M 24	20	585	M 27	20	111	-	-	93.350	65	93.450	65	93.450
Ø 500	408	435	127	667	26	142	-	-	315	400	16	22x4	Ø 45	92	165	620	M 24	20	650	M 30	20	148	-	-	93.350	65	93.450	65	93.450
Ø 600	482	519	154	768	26	142	-	-	315	400	16	22x4	Ø 60	92	165	725	M 27	20	770	M 33	20	225	-	-	93.450	65	93.450	65	93.450
Ø 700	543	548	165	900	30	142	-	-	414	400	25	18x8	Ø 68	118	254	840	M 27	24	840	M 33	24	323	-	-	93.450	210	93.450	210	93.450
Ø 800	587	587	180 / 190	1016	30	157	-	-	414	400	25	18x8	Ø 80	118	254	950	M 30	24	950	M 36	24	413	-	-	93.550	210	93.550	210	93.550